

APN

High head impeller

All product images are indicative only



General characteristics

High head impeller	
motor power	1,8 ÷ 4,1 kW
poles	2
discharge	GAS 1½" -2" DN32 horizontal
free passage	max 10 mm
max flow rate	10 l/s
max head	38.7 m

Electromechanical assembly

Electromechanical assembly in GJL-250 cast iron, for submerged operation. Seal set comprising 2 (two) opposing silicon carbide mechanical seals in inspectable oil sump. Ecological dry motor. Series available in explosion-proof ATEX version.

Applications

Suitable for clear wastewater, rainwater and seepage. The considerable manometric head guarantees excellent results for the creation of water features and decorative fountains; suitable for use in agriculture, irrigation and the fish processing sector. The pump is also available in explosion-proof version with ATEX certification. This series is prefitted for installation of the ZENIT cooling system for dry or semi-submerged installation.

Construction materials

Case	Cast iron EN-GJL 250
Impeller material	Cast iron EN-GJL-250
Nuts and bolts	Stainless steel - Class A2-70
Standard gasket	Rubber - NBR
Shaft	Stainless steel - AISI 420
Cooling jacket	Stainless steel - AISI 304
Paint type	Ecological bicomponent epoxy (medium thickness 150 µm)
Set of standard mechanical seals	Two silicon carbide mechanical seals (2SiC)

Operating limits

Maximum operating temperature	40 °C
PH of treated fluid	6 ÷ 14
Viscosity of treated fluid	1 mm ² /s
Maximum immersion depth	20 m
Density of treated fluid	1 Kg/dm ³
Maximum acoustic pressure	70 dB
max starts per hour	30

APN



Cooling system

Dry installation available using the cooling jacket (see details to page 17)



Cable gland

Cable gland system to guarantee perfect water-tightness. The GAS thread ring-nut can be removed to fix a rigid or flexible duct to the cable gland to protect the power supply cable.



Mechanical seals

Two silicon carbide (2SiC) mechanical seals in oil sump.



Oil sump

Large oil sump to guarantee longer mechanical seal lifetime.



Anti-clogging system

The special design of the hydraulic part ensures the expulsion of suspended solids and prevents fouling of the impeller.



Intake strainer

Intake strainer in stainless steel.

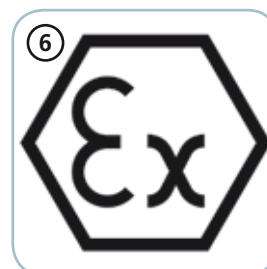

EX

Models available on request with ATEX certification, suitable for installation in the presence of potentially explosive gases, powders and liquids.

CE 0496 Ex II 2GD Ex db k c IIB T5 Ex tb IIIC T100°C IP68

APN

Models with horizontal GAS 1½" threaded - DN32 PN6 flanged discharge - 2 poles

Performances

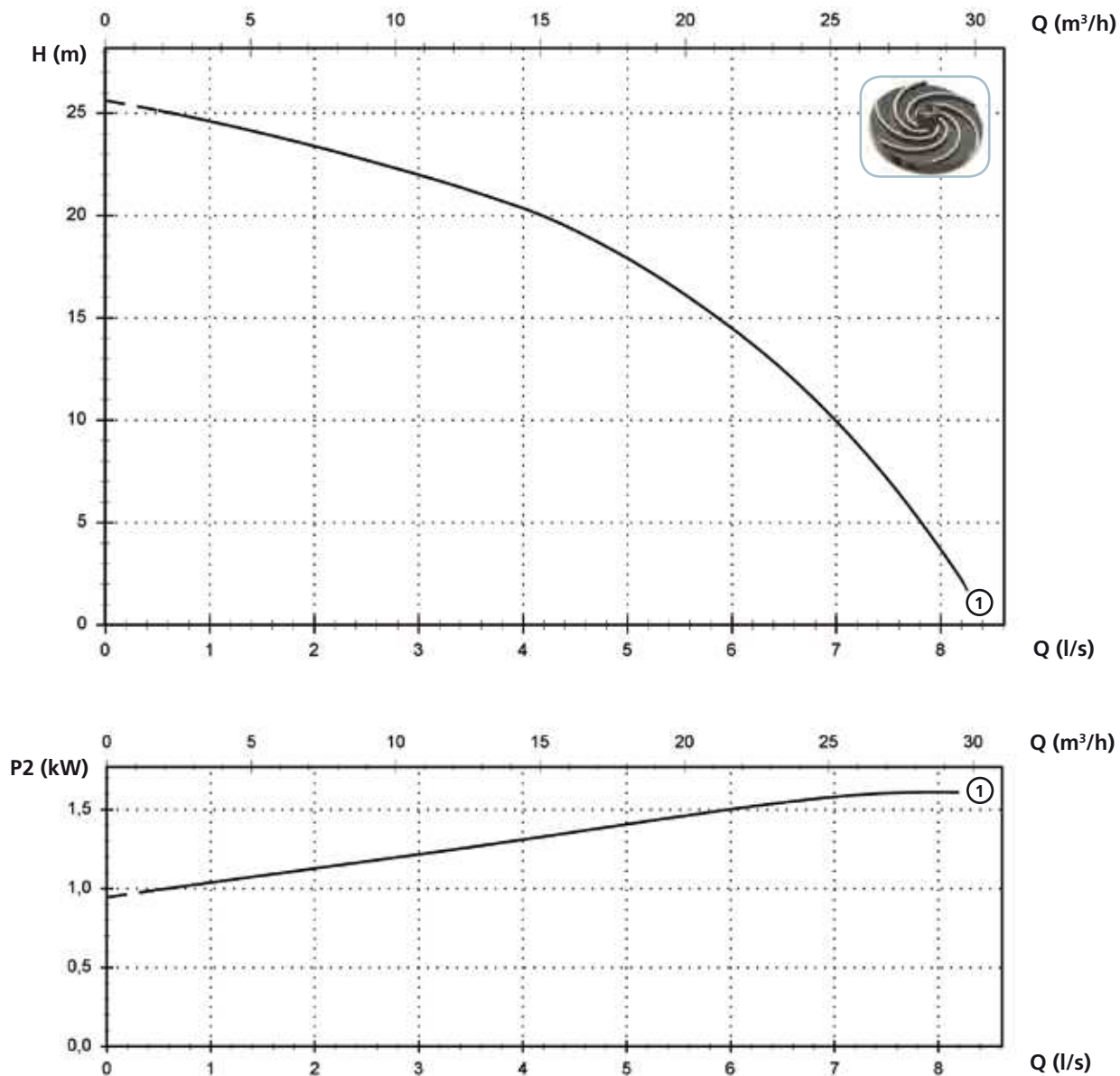

Technical data

	V	Phases	P1 (kW)	P2 (kW)	A	Rpm	Start	Ø	Free passage
① APN 250/2/G40H A1DM/50	230	1	2.7	1.8	12.5	2900	Dir	G 1½"-DN32 PN6	10 mm
① APN 250/2/G40H A1DT/50	400	3	2.5	1.8	4.3	2900	Dir	G 1½"-DN32 PN6	10 mm

Models with horizontal GAS 2" threaded - DN32 PN6 flanged discharge - 2 poles

Performances

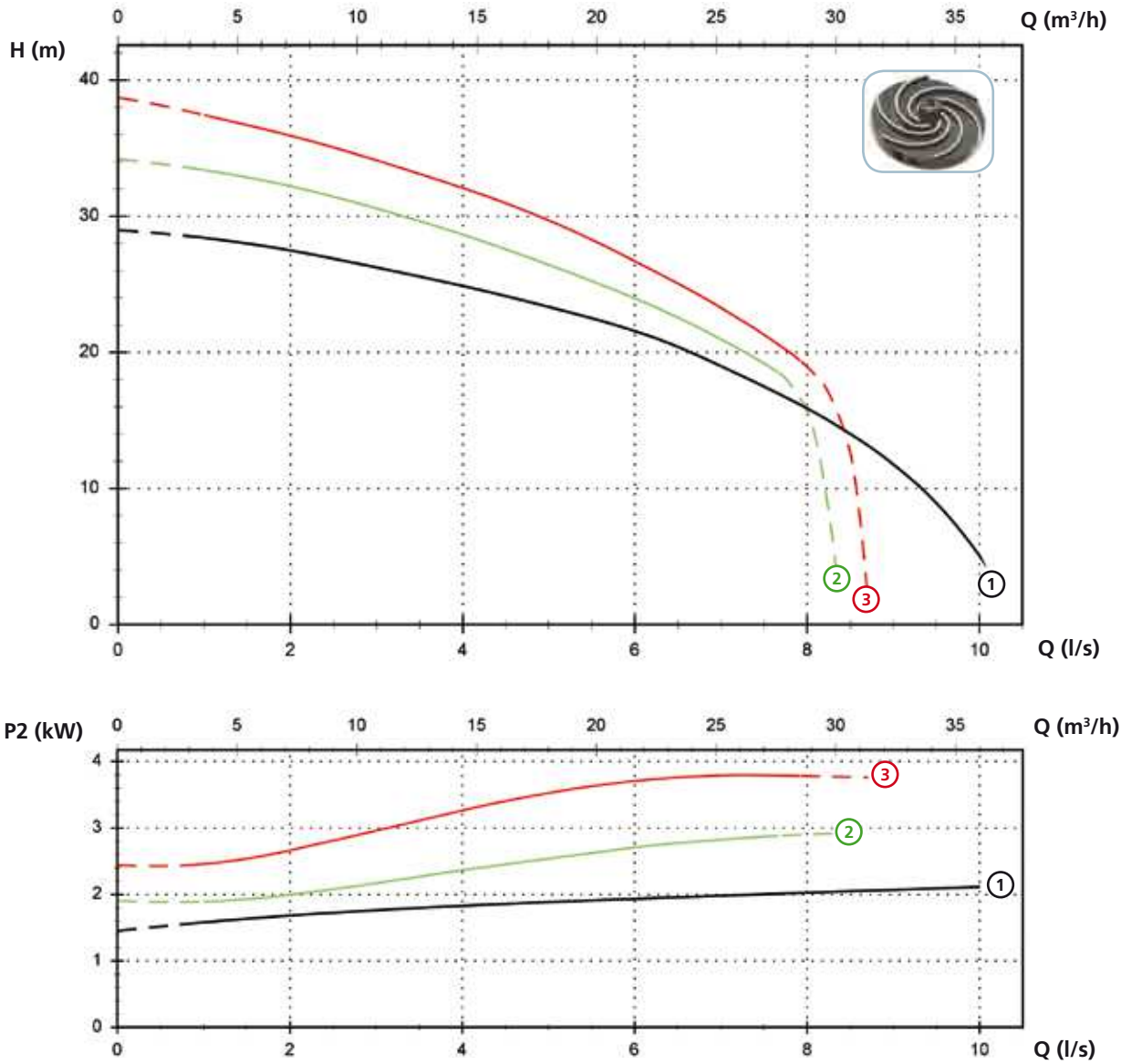

Technical data

	V	Phases	P1 (kW)	P2 (kW)	A	Rpm	Start	Ø	Free passage
① APN 300/2/G50H A1DT/50	400	3	3.7	2.2	5.1	2900	Dir	G 2"- DN32 PN6	10 mm
② APN 400/2/G50H A1FT/50	400	3	4.0	3	6.7	2900	Dir	G 2"- DN32 PN6	10 mm
③ APN 550/2/G50H A1FT/50	400	3	5.0	4.1	8.7	2900	Dir	G 2"- DN32 PN6	10 mm

APN

Versions available

(Key to versions on page 16)

	Electrical variants											Cooling				Mechanical seals				
	N A E	T	T C	T C D	T C D T	T C D G T	T C G	T C S T	T C S G T	T S	T R	T R G	N	CC CCE	FT	C G F T	2SIC	SICM	SICAL	2SICAL
APN 250/2/G40H A1DM/50				●								●	●			●				
APN 250/2/G40H A1DT/50		●							●			●	●			●				
APN 300/2/G50H A1DT/50		●							●			●	●			●				
APN 400/2/G50H A1FT/50		●							●			●	●			●				
APN 550/2/G50H A1FT/50		●							●			●	●			●				

NOTE FOR SINGLE PHASE PUMPS: thermal protections into the winding have to be connected to the electrical panel.
 Start capacitor inside the pump. Circuit breaker supplied but not connected to the pump cable.
 The use of an electrical panel as circuit breaker housing is mandatory.
 For installation please see use and maintenance instructions booklet.

Overall dimensions and weights

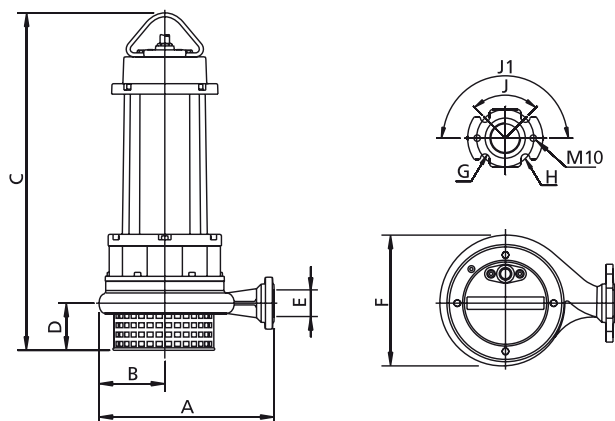

	A	B	C	D	E	F	G	H	J	J1	kg
APN 250/2/G40H A1DM(T)/50	265	105	530	80	G 1½"	215	14	90	90°	180°	43
APN 300/2/G50H A1DT/50	305	110	530	80	G 2"	225	14	90	90°	180°	46
APN 400/2/G50H A1FT/50	350	130	660	80	G 2"	265	14	90	90°	180°	68
APN 550/2/G50H A1FT/50	350	130	660	80	G 2"	265	14	90	90°	180°	71

Dimensions in mm

All weights and dimensions are indicative only

Packaging dimension

	A	B	C
APN 250/2/G40H A1DM(T)/50	725	445	415
APN 300/2/G50H A1DT/50	725	445	415
APN 400/2/G50H A1FT/50	725	445	415
APN 550/2/G50H A1FT/50	725	445	415

Dimension in mm

All weights and dimensions are indicative only

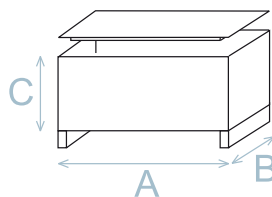

Installations available

