

GRN

Impeller with grinder system

All product images are indicative only



General characteristics

Impeller with grinder system	
motor power	1,8 ÷ 4,1 kW
poles	2 / 4
discharge	GAS 1 1/2" - 2" DN32 horizontal DN80 - DN100
free passage	-
max flow rate	29.6 l/s
max head	47.6 m

Electromechanical assembly

Electromechanical assembly in GJL-250 cast iron, for submerged operation. Seal set comprising 2 (two) opposing silicon carbide mechanical seals in inspectable oil sump. Ecological dry motor. Series available in explosion-proof ATEX version.

Applications

Designed for professional and industrial use, it is suitable for the treatment of liquids containing suspended solids or fibres, and low or medium density activated sludges. The pump is also available in explosion-proof version with ATEX certification. This series is prefitted for installation of the ZENIT cooling system for dry or semi-submerged installation.

Construction materials

Case	Cast iron EN-GJL 250
Impeller	Cast iron EN-GJL-250
Nuts and bolts	Stainless steel - Class A2-70
Standard gasket	Rubber - NBR
Cutter material	Chromium steel - X102 CrMo17 KU
Cutting disk material	Chromium steel - X102 CrMo17 KU
Shaft	Stainless steel - AISI 420
Cooling jacket	Stainless steel - AISI 304
Paint type	Ecological bicomponent epoxy (medium thickness 150 µm)
Set of standard mechanical seals	Two silicon carbide mechanical seals (2SiC)

Operating limits

Maximum operating temperature	40 °C
PH of treated fluid	6 ÷ 14
Viscosity of treated fluid	1 mm ² /s
Maximum immersion depth	20 m
Density of treated fluid	1 Kg/dm ³
Maximum acoustic pressure	70 dB
max starts per hour	30

GRN

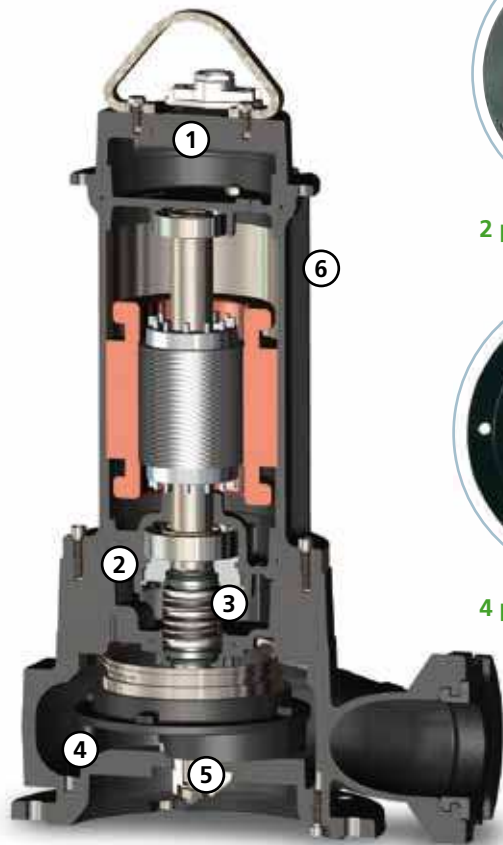

2 poles motor models

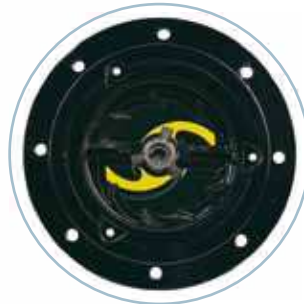

4 poles motor models



Cooling system

Dry installation available using the cooling jacket (see details to page 17)



Cable Gland

Cable gland system to guarantee perfect water-tightness. The universal thread ring-nut can be removed to fix a rigid or flexible duct to the cable gland to protect the power supply cable



Mechanical seals

Two silicon carbide (SiC) mechanical seals in oil sump



Oil sump

Large oil sump to guarantee longer mechanical seal lifetime



Anti-clogging system

The special design of the hydraulic part ensures the expulsion of suspended solids and prevents fouling of the impeller



Grinder system

Grinder system comprising a revolving cutter and a plate with holes with sharpened edges (2 pole models) or a cast iron flange with saw-tooth edges (4 pole models) that fine-chops filaments, preventing fouling of the impeller

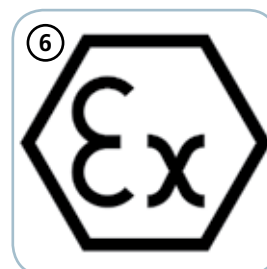

EX

Models available on request with ATEX certification, suitable for installation in the presence of potentially explosive gases, powders and liquids

CE 0496 Ex II 2GD Ex db k c IIB T5 Ex tb IIIC T100°C IP68

GRN

Models with horizontal GAS 1 1/2" threaded - DN32 PN6 flanged discharge - 2 poles

Performances

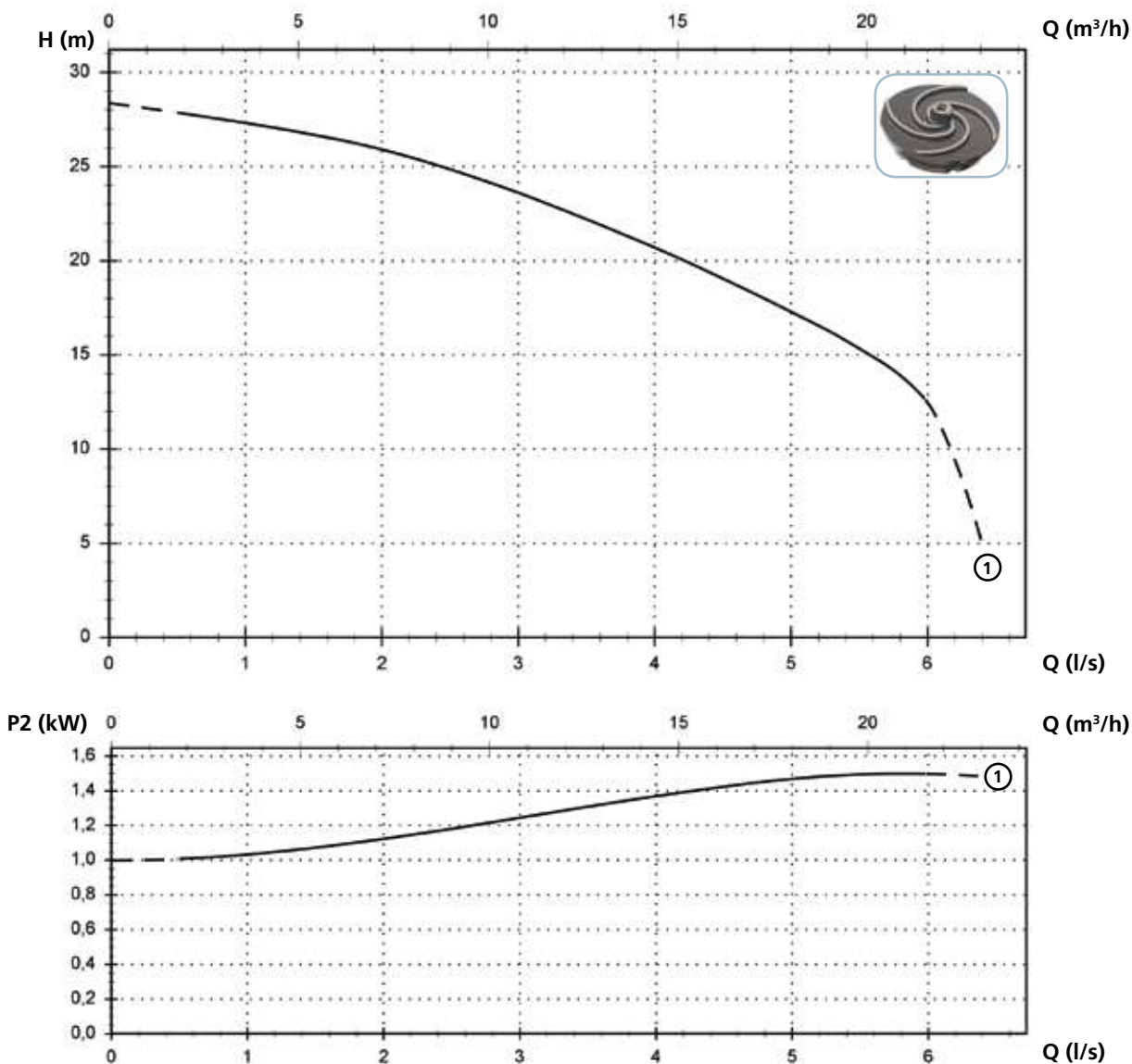

Technical data

	V	Phases	P1 (kW)	P2 (kW)	A	Rpm	Start	Ø	Cable (*)	Free passage
① GRN 250/2/G40H A1DM/50	230	1	2.7	1.8	12.5	2900	Dir	G 1 1/2" - DN32 PN6	A - B	-
① GRN 250/2/G40H A1DT/50	400	3	2.3	1.8	3.9	2900	Dir	G 1 1/2" - DN32 PN6	A - B	-

(*) A = 07RN-F 4G1.5+3x1 - 10 m (standard version). Electrical and mechanical features are equal to the cable H07RN-F
 B = NSSHOU-J 4G1.5+2x0.75 - 10 m (ATEX version)

Models with horizontal GAS 2" threaded - DN32 PN6 flanged discharge - 2 poles

Performances

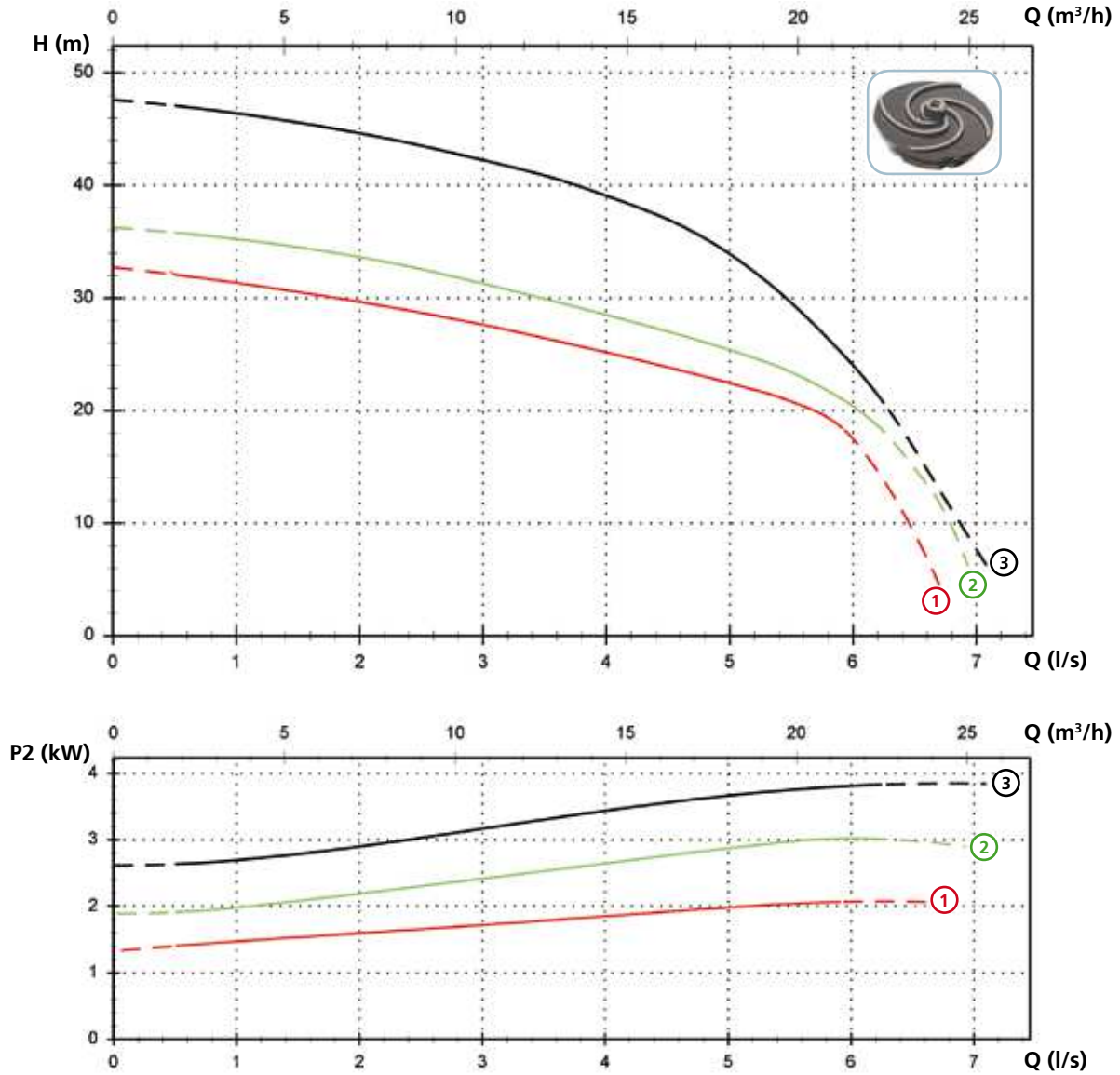

Technical data

	V	Phases	P1 (kW)	P2 (kW)	A	Rpm	Start	Ø	Cable (*)	Free passage	
①	GRN 300/2/G50H A1DT/50	400	3	2.9	2.2	5.1	2900	Dir	G 2"-DN32 PN6	A - B	-
②	GRN 400/2/G50H A1FT/50	400	3	4.0	3	6.7	2900	Dir	G 2"-DN32 PN6	A - C	-
③	GRN 550/2/G50H A1FT/50	400	3	5.0	4.1	8.7	2900	Dir	G 2"-DN32 PN6	A - C	-

(*) A = 07RN-F 4G1.5+3x1 - 10 m (standard version). Electrical and mechanical features are equal to the cable H07RN-F
 B = NSSHOU-J 4G1.5+2x0.75 - 10 m (ATEX version)
 C = NSSHOU-J 4G2.5+2x0.75 - 10 m (ATEX version)

GRN

Models with horizontal DN80 PN10-16 flanged discharge - 4 poles

Performances

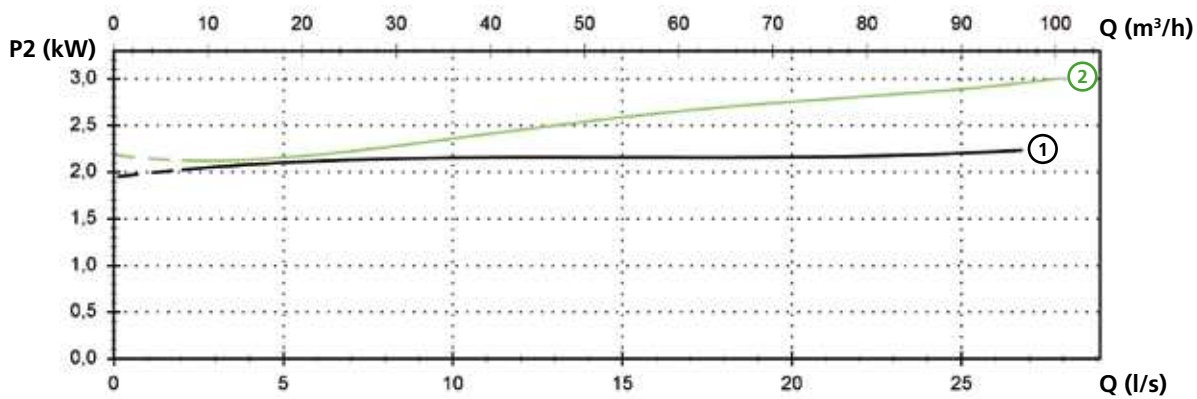
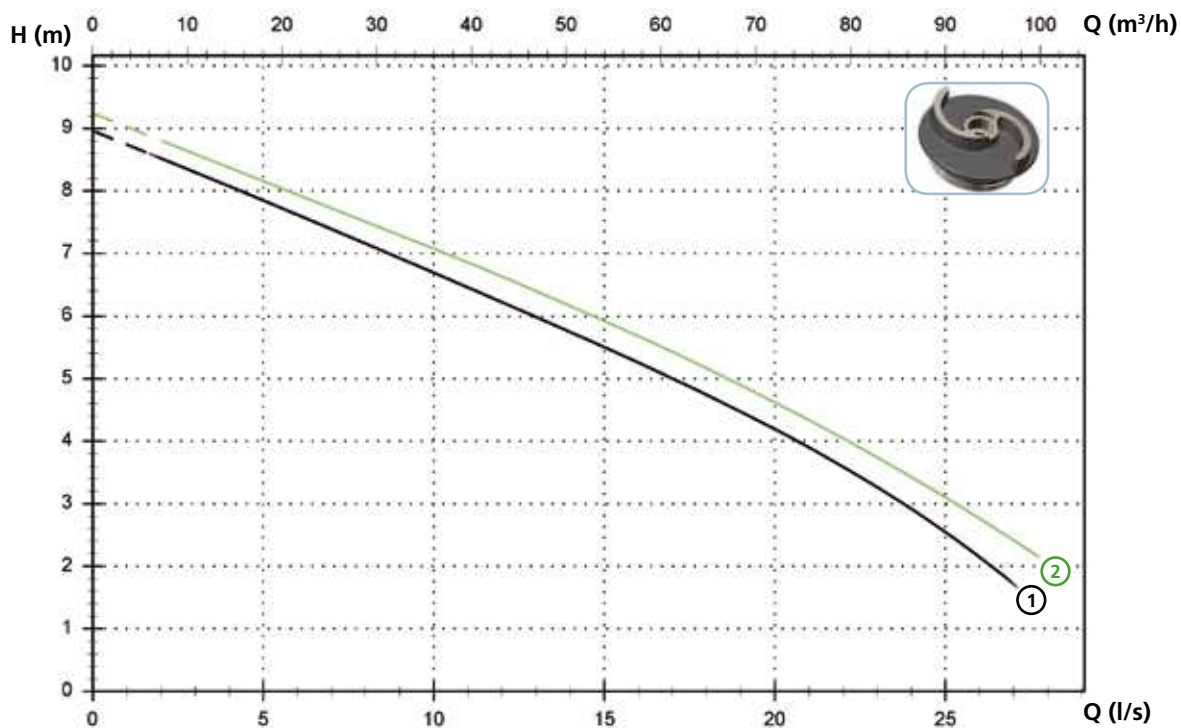

Technical data

	V	Phases	P1 (kW)	P2 (kW)	A	Rpm	Start	Ø	Cable (*)	Free passage	
①	GRN 300/4/80 A1FT/50	400	3	2.9	2.2	5.8	1450	Dir	DN80 PN10-16	A - B	-
②	GRN 400/4/80 A1FT/50	400	3	3.7	3	7.3	1450	Dir	DN80 PN10-16	A - B	-

(*) A = 07RN-F 4G1.5+3x1 - 10 m (standard version). Electrical and mechanical features are equal to the cable H07RN-F
 B = NSSHOU-J 4G2.5+2x0.75 - 10 m (ATEX version)

Models with horizontal DN100 PN10-16 flanged discharge - 4 poles

Performances

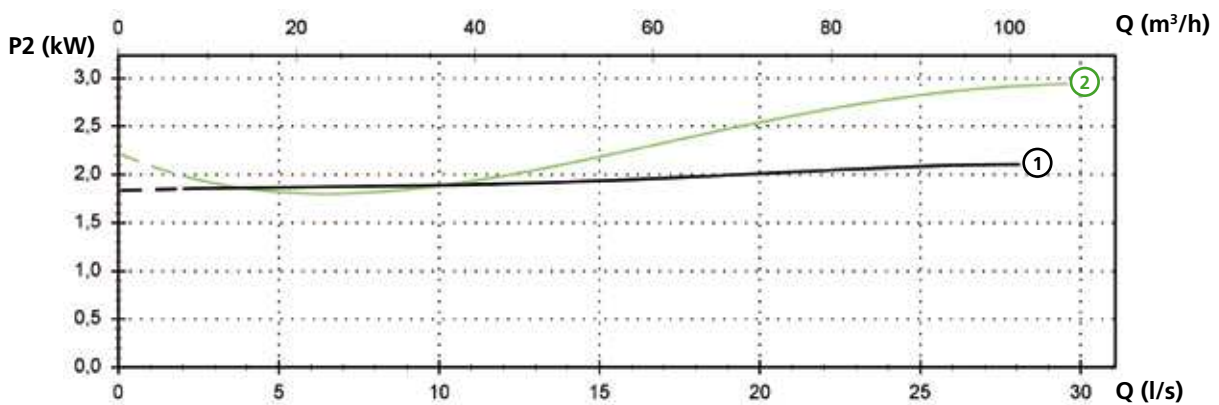
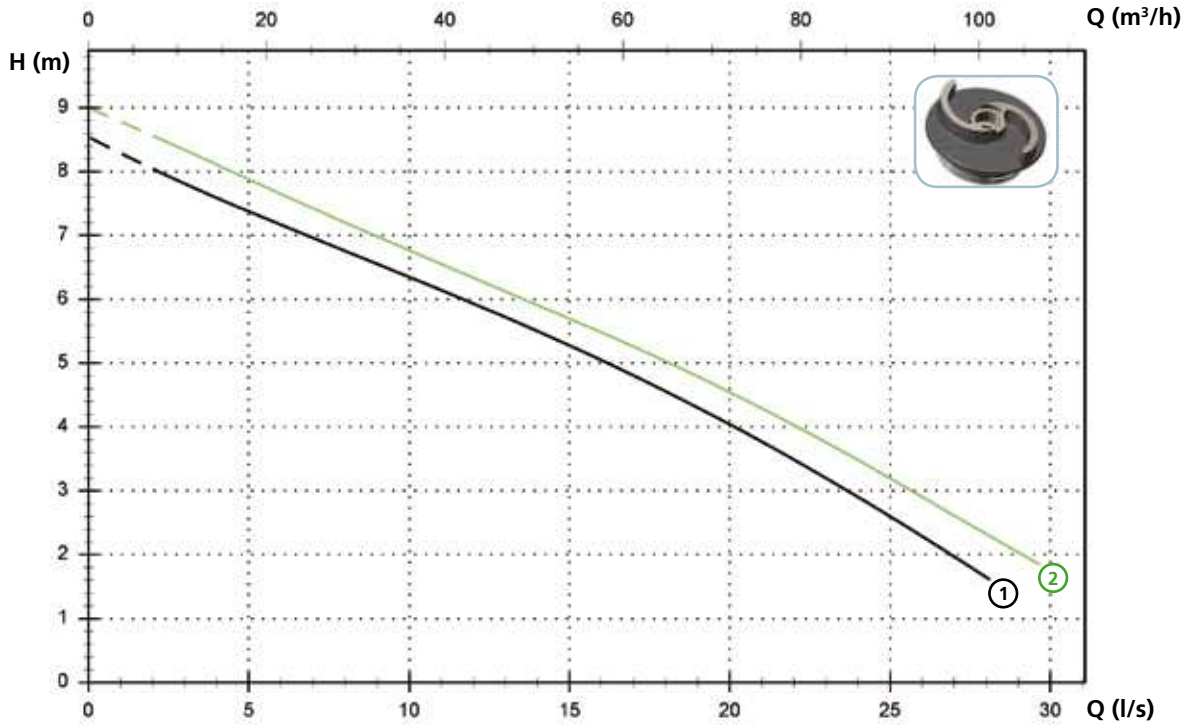

Technical data

	V	Phases	P1 (kW)	P2 (kW)	A	Rpm	Start	Ø	Cable (*)	Free passage	
①	GRN 300/4/100 A1FT/50	400	3	2.9	2.2	5.8	1450	Dir	DN100 PN10-16	A - B	-
②	GRN 400/4/100 A1FT/50	400	3	3.7	3	7.3	1450	Dir	DN100 PN10-16	A - B	-

(*) A = 07RN-F 4G1.5+3x1 - 10 m (standard version). Electrical and mechanical features are equal to the cable H07RN-F
 B = NSSHOU-J 4G2.5+2x0.75 - 10 m (ATEX version)

GRN

Versions available

(Key to versions on page 16)

	Electrical variants											Cooling				Mechanical seals				
	N A E	T	T C	T C D	T C D T	T C D G T	T C G	T C S T	T C S G T	T S	T R	T R G	N	CC CCE	FT	C G F T	2SIC	SICM	SICAL	2SICAL
GRN 250/2/G40H A1DM/50				●									●	●			●			
GRN 250/2/G40H A1DT/50		●							●				●	●			●			
GRN 300/2/G50H A1DT/50		●							●				●	●			●			
GRN 400/2/G50H A1FT/50		●							●				●	●			●			
GRN 550/2/G50H A1FT/50		●							●				●	●			●			
GRN 300/4/80 A1FT/50		●							●				●	●			●			
GRN 400/4/80 A1FT/50		●							●				●	●			●			
GRN 300/4/100 A1FT/50		●							●				●	●			●			
GRN 400/4/100 A1FT/50		●							●				●	●			●			

NOTE FOR SINGLE PHASE PUMPS: thermal protections into the winding have to be connected to the electrical panel.
 Start capacitor inside the pump.
 Circuit breaker supplied but not connected to the pump cable.
 The use of an electrical panel as circuit breaker housing is mandatory.
 For installation please see use and maintenance instructions booklet.

Overall dimensions and weights

2 poles motor models

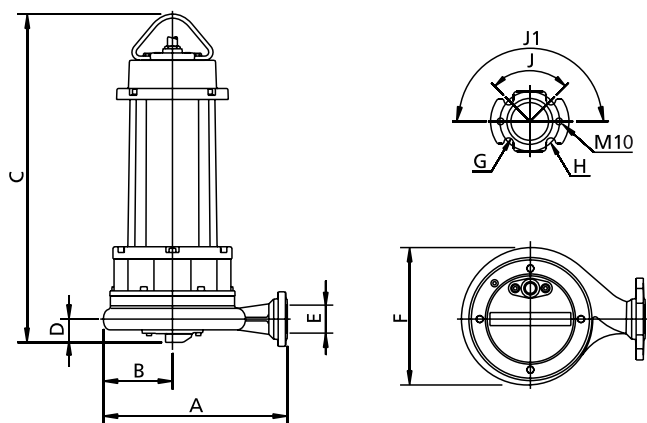

	A	B	C	D	E	F	G	H	J	J1	kg
GRN 250/2/G40H A1DM/50	265	105	495	45	G 1 1/2"	215	14	90	90°	180°	44
GRN 250/2/G40H A1DT/50	265	105	495	45	G 1 1/2"	215	14	90	90°	180°	44
GRN 300/2/G50H A1DT/50	305	110	500	45	G 2"	225	14	90	90°	180°	44
GRN 400/2/G50H A1FT/50	350	130	630	45	G 2"	265	14	90	90°	180°	69
GRN 550/2/G50H A1FT/50	350	130	630	45	G 2"	265	14	90	90°	180°	72

Dimensions in mm

All weights and dimensions are indicative only

4 poles motor models

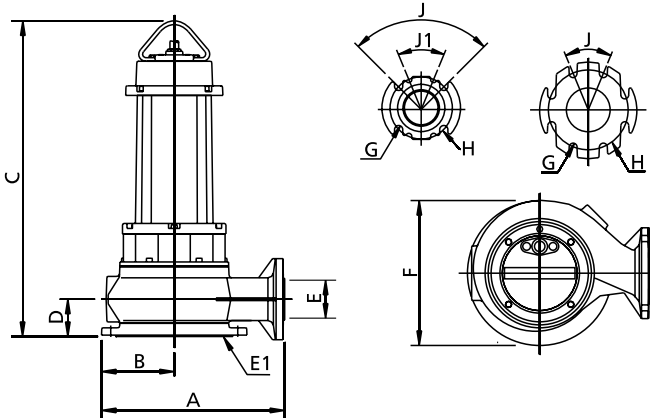

	A	B	C	D	E	E1 (*)	F	G	H	J	J1	kg
GRN 300/4/80 A1FT/50	400	160	695	80	80	200	290	18	160	90°	45°	87
GRN 400/4/80 A1FT/50	400	160	695	80	80	200	290	18	160	90°	45°	90
GRN 300/4/100 A1FT/50	415	160	700	90	100	200	310	18	180	45°	-	89
GRN 400/4/100 A1FT/50	415	160	700	90	100	200	310	18	180	45°	-	92

Dimensions in mm

All weights and dimensions are indicative only

(*) DN of the suction flange - PN6

Packaging dimension

	A	B	C
GRN 250/2/G40H A1DM(T)/50	725	445	415
GRN 300/2/G50H A1DT/50	725	445	415
GRN 400/2/G50H A1FT/50	725	445	415
GRN 550/2/G50H A1FT/50	725	445	415
GRN 300/4/80 A1FT/50	725	445	415
GRN 400/4/80 A1FT/50	725	445	415
GRN 300/4/100 A1FT/50	725	445	415
GRN 400/4/100 A1FT/50	725	445	415

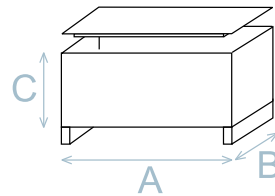

Dimension in mm

All weights and dimensions are indicative only

Installations available

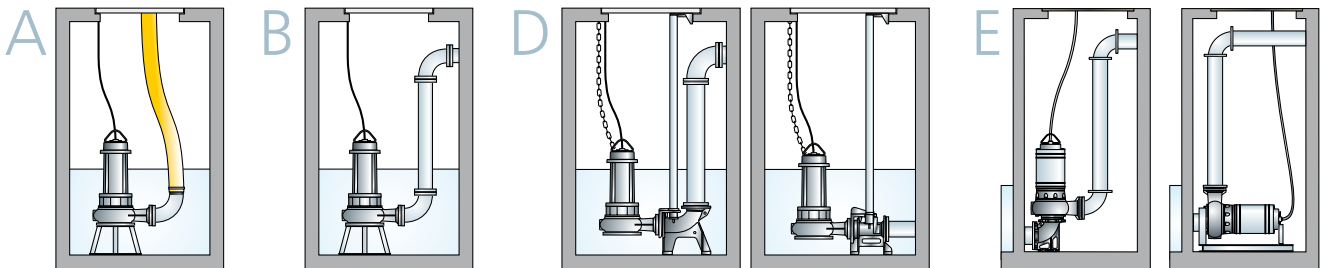

4 poles motor models