



II 2/2GD c IIB T135°C (zone1)  
II 3/3GD c IIB T135°C (zone2)

**3A certified, made with mechanically polished Aisi316, the SANIBOXER pump is designed for the Food-Processing, Cosmetic and Pharmaceutical industry.**

### APPLICATIONS

The SANIBOXER pneumatic diaphragm pumps have been designed and built to pump liquid foodstuffs using materials that are compatible with the chemical substances used to clean and sanitize the pump.

The pump may be used at operating temperatures (temperature of the fluid + environmental temperature) compatible with the pump materials and in any case never exceeding 95°C.

### WORKING PRINCIPLE

The SANIBOXER diaphragm pumps consist of a centrally lodged coaxial pneumatic motor with diaphragms fixed to its shaft.

The ball valves and the seats of the suction and delivery lines are located on the ends of the two pump bodies.

The compressed air injected by the coaxial exchanger behind one of the two diaphragms determines the compression and pushes the product in the delivery line.

At the same time the diaphragm, integral with the exchanger's shaft, creates a depression while sucking the fluid.

Once the run is completed, the pneumatic coaxial exchanger deviates the compressed air behind the opposite diaphragm and the cycle reverses automatically.



### EASY-CLEAN VALVE

Patent system



**Aisi 316**  
mechanically polished  
**RA < 0,8µm**



### FAST EMPTYING SYSTEM

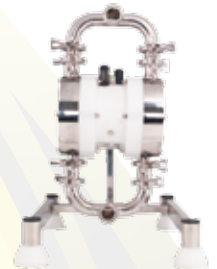
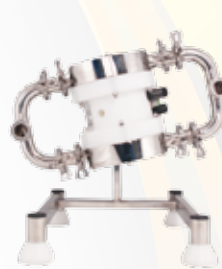

#### Self-priming

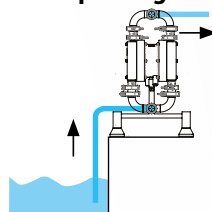

#### Positive suction head

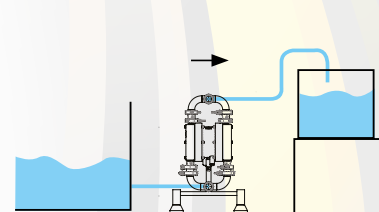

# SANIBOXER 100



Mechanically polished Aisi316

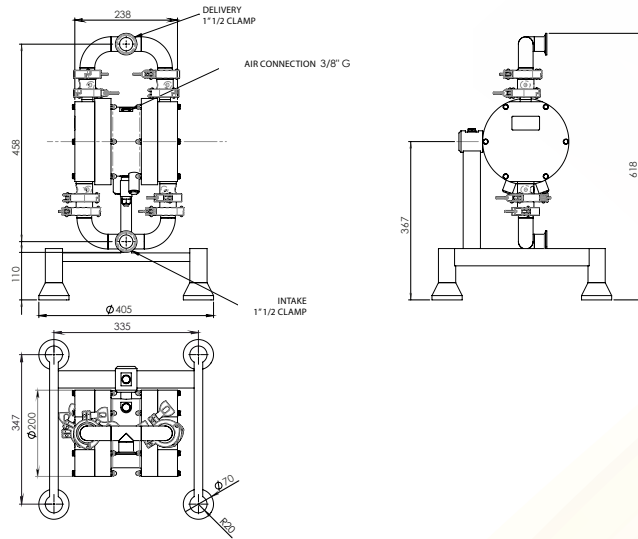

Suction/delivery connections	1"1/2 clamp
Air connection	3/8"
Air pressure (max.)	7 bar
Max. operating temperature (fluid + amb.)	95°C
Dry suction capacity (PTFE diaphragm)	4m
Max flow rate (water at 18°C with immersed intake manifold)	120 l/m
Net weight (empty)	26 KG
Max. diameter of passing solids	4 mm

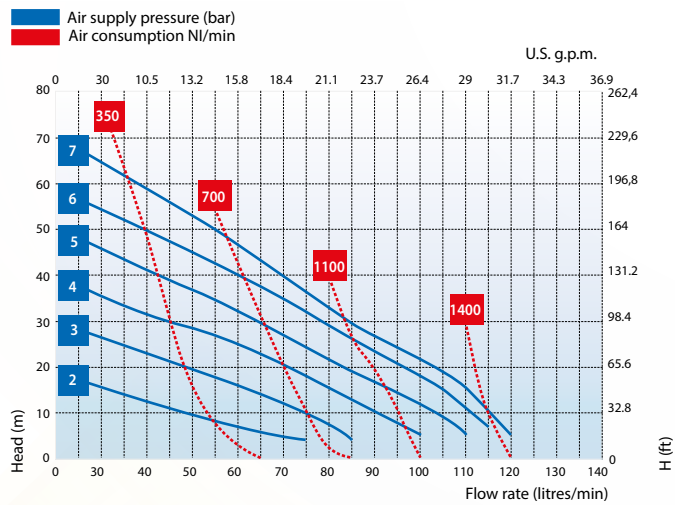

## ACCESSORIES - DIAPHRAGM LEAKER SENSOR

This system designed to be used by SANIBOXER diaphragm pumps, is provided with a self-diagnosis function for the contacts and the right operation of the circuit. In the event of a malfunction, the red pilot lamp always lits up and, depending on the irregularity the audible alarm will activate too.

The control unit operates exclusively during the pumping of conductive fluids; it detects the diaphragm breakage through the contacts placed behind the diaphragms, inside the compression chamber. When the liquid stands between the two sensors, it causes the closing of the electric circuit placed inside the control unit and consequently the switching off of the output relay, deactivating then the solenoid valve which controls the pump, stopping its operation and enabling both a visual and acoustic alarm.

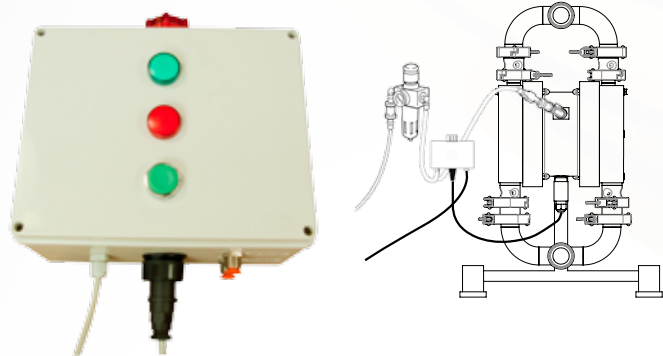

## COMPOSITION CODES

es. SB100A-DTTAT-

Saniboxer 100 in Aisi316, diaphragm EPDM, diaphragm PTFE, balls Aisi 316 + ball seats Aisi316. O-Ring PTFE

SB100	A -	D	T	T	A	T	-
<b>Pump model</b>	<b>Pump body</b>	<b>Single diaphragm</b>		<b>Balls</b>	<b>Ball seats</b>	<b>O-Ring</b>	
SB 100 = SANIBOXER 100	A - AISI 316 electropolished	<b>Air side</b>	<b>Fluid side</b>	T - PTFE A - Aisi 316	A - AISI 316		
		D - EPDM	T - PTFE				

DIAPHRAGM PUMPS - 3A