

High effective motor competent to pump highly laden mud water. The impeller and agitator is made of high chrome alloy ensure great durability. Semi Vortex impeller design reduce the clogging situation by sand.

Specification

Civil engineering, building sites, basements or utility pits, rainwater, mud water and fluid with high abrasive

Application

- Water temperature: up to 40°C
- PH: 6.5 to 8.5
- Power supply: Single phase 220V ± 10%, 50Hz, 60Hz
- Insulation class: F
- Protection class: IP 68
- Maximum immersion depth: 10m
- Cable length: 8m

Special features on request

- Other voltages

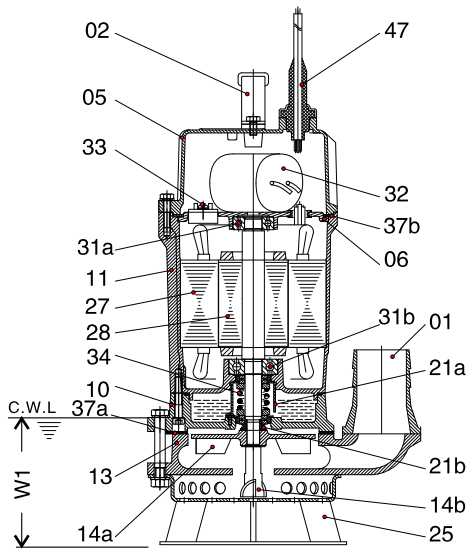

W1: Continuous running water level

Materials of construction

Item No.	Part name	Material
01	Hose coupling	Cast iron
02	Handle	Rubber&AISI304SS
05	Upper cover	Aluminum die casting
06	Up-Bearing house	Cast iron
10	Seal house	Cast iron
11	Motor body	Aluminum die casting
13	Pump body	Cast iron
14a	Impeller	High chrome alloy
14b	Agitator	High chrome alloy
21a	Oil riser	LDPE
21b	Sand guard	NBR
25	Strainer	Steel
27	Stator	
28	Rotor	Shaft:AISI420SS
31a	Bearing	Ball bearing
31b	Bearing	Ball bearing
32	Capacitor	
33	Motor protector	
34	Mechanical seal	Ceramic-Sic/Carbon-Ceramic
37a	Gasket	NBR
37b	Gasket	NBR
47	Cable	H07RN-F

Performance curves

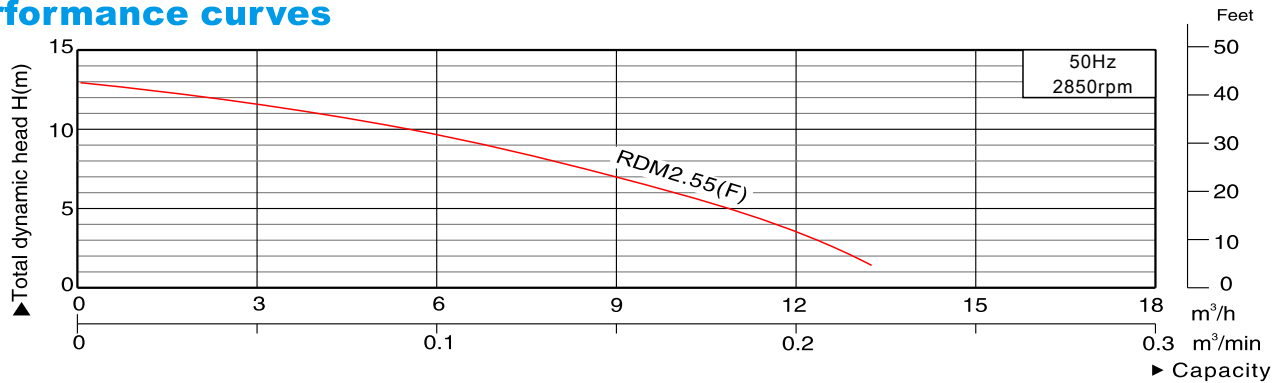

Model	Outlet	Motor power		Max head	Max capacity		Impeller passage	W1	N.W	G.W	Packing dimension
	mm	kW	HP	m	m³/h	m³/min	mm	mm	Kg	Kg	
RDM2.55(F)	50	0.55	0.75	13	13.2	0.22	9	95	15.5	16.5	455X255X230

●(F): Float switch