

-  Sewage water
-  Domestic use
-  Civil use
-  Industrial use



PERFORMANCE RANGE

- Flow rate up to **1600 l/min** (96 m³/h)
- Head up to **25 m**

APPLICATION LIMITS

- **10 m** maximum immersion depth (with a sufficiently long power cable)
- Maximum liquid temperature **+40 °C**
- Passage of solids:
 - up to **Ø 50 mm** for MC /50-F
 - up to **Ø 70 mm** for MC /70-F
- Minimum immersion depth for continuous service:
 - **390 mm** for MC /50-F
 - **440 mm** for MC /70-F

CONSTRUCTION AND SAFETY STANDARDS

- **10 m** long power cable
- External float switch and control box for single-phase versions

EN 60335-1
IEC 60335-1
CEI 61-150

EN 60034-1
IEC 60034-1
CEI 2-3



CERTIFICATIONS

Company with management system certified DNV
ISO 9001: QUALITY



INSTALLATION AND USE

The **MC-F** series of pumps, manufactured from heavy gauge robust cast iron, resistant to abrasion and long lasting, are fitted with a **DOUBLE CHANNEL** impeller in stainless steel which allows the drainage of liquids with short fibre solids in suspension. They are suitable for carrying **discharged and sewer water, dirty water, water mixed with mud, groundwater** and surface water, for applications, when placed in suitable wells, in blocks of flats, public buildings, industries, multi-storey and underground car parks and wash areas.

OPTIONS AVAILABLE ON REQUEST

- Connection support KIT
- QES control box for three-phase pumps
- Single-phase pumps without float switch
- Other voltages or 60 Hz frequency

GUARANTEE

➔ **For the following versions the incorporated thermal overload protector must be connected to the control box for the guarantee to be considered valid:**

single-phase
– MCm 30/50-F
– MCm 30/70-F

three-phase
– MC 15-20-30-40/50-F
– MC 30-40/70-F

CHARACTERISTIC CURVES AND PERFORMANCE DATA

50 Hz n= 2900 min⁻¹

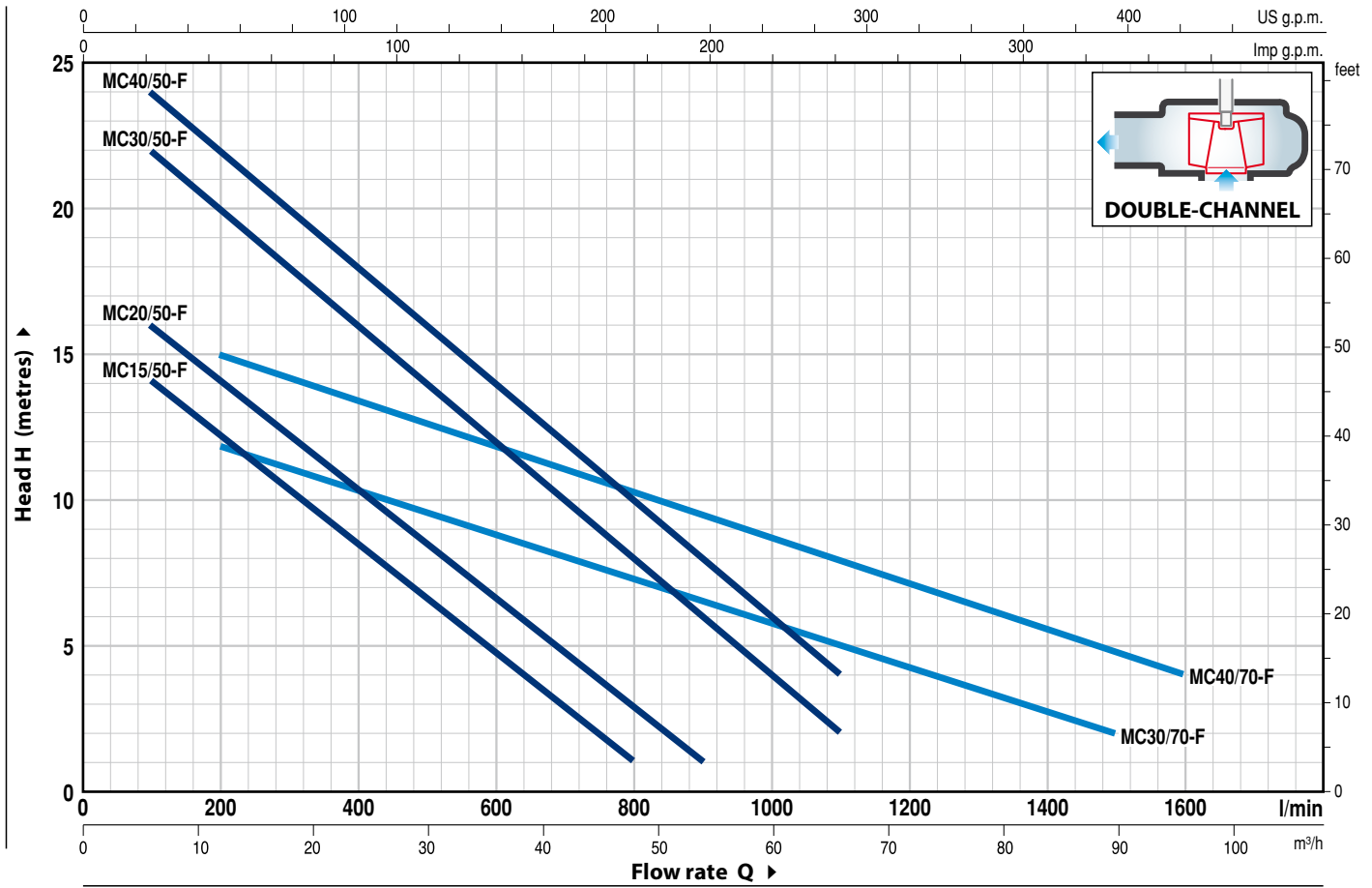

MODEL		POWER (P ₂)		Q	Flow rate Q															
Single-phase	Three-phase	kW	HP		m ³ /h	0	6	12	18	24	30	36	42	48	54	60	66	72	90	96
				l/min	0	100	200	300	400	500	600	700	800	900	1000	1100	1200	1500	1600	
MCm 15/50-F	MC 15/50-F	1.1	1.5	H metres	16	14	12.5	10.5	8.5	6.5	4.5	3	1							
MCm 20/50-F	MC 20/50-F	1.5	2		18	16	14	12.5	10.5	8.5	6.5	5	3	1						
MCm 30/50-F	MC 30/50-F	2.2	3		24	22	20	18	16	14	12	10	8	6	4	2				
-	MC 40/50-F	3	4		25	24	22	20	18	16	14	12	10	8	6	4				
MCm 30/70-F	MC 30/70-F	2.2	3		13	-	12	11	10.5	9.7	9	8	7.5	6.5	6	5	4.5	2		
-	MC 40/70-F	3	4		17	-	15	14	13.5	12.5	12	11	10.5	9.5	8.5	8	7	4.8	4	

Q = Flow rate H = Total manometric head

Tolerance of characteristic curves in compliance with EN ISO 9906 Grade 3B.

POS. COMPONENT CONSTRUCTION CHARACTERISTICS

1	PUMP BODY	Cast iron complete with flanged ports
2	SUCTION PLATE	Cast iron
3	IMPELLER	Precision cast stainless steel AISI 304 DOUBLE-CHANNEL type
4	MOTOR CASING	Cast iron
5	MOTOR CASING PLATE	Cast iron
6	MOTOR SHAFT	Stainless steel AISI 431

7 TWO MECHANICAL SEALS SEPARATED BY AN OIL CHAMBER

Seal Model	Shaft Diameter	Position	Materials		
			Stationary ring	Rotational ring	Elastomer
STA-20	Ø 20 mm	Motor side	Ceramic	Graphite	NBR
STA-19	Ø 19 mm	Pump side	Silicon carbide	Silicon carbide	NBR

8 BEARINGS 6304 ZZ - C3 / 6304 ZZ - C3

9 CAPACITOR

Pump	Capacitance
Single-phase	(220-230 V o 240 V)
MCm 15/50-F	31.5 µF 450 VL
MCm 20/50-F	50 µF 450 VL
MCm 30/50-70-F	60 µF 450 VL

10 ELECTRIC MOTOR

MCm 15-20-F: single-phase 220-230 V - 50 Hz with thermal overload protector incorporated into the winding

⇒ **MCm 30-F:** single-phase 220-230 V - 50 Hz with thermal overload protector incorporated into the winding to be connected to the control box

⇒ **MC-F:** three-phase 400 V - 50 Hz with thermal overload protector incorporated into the winding to be connected to the control box (supplied on demand)

– Insulation: class F

– Protection: IP X8

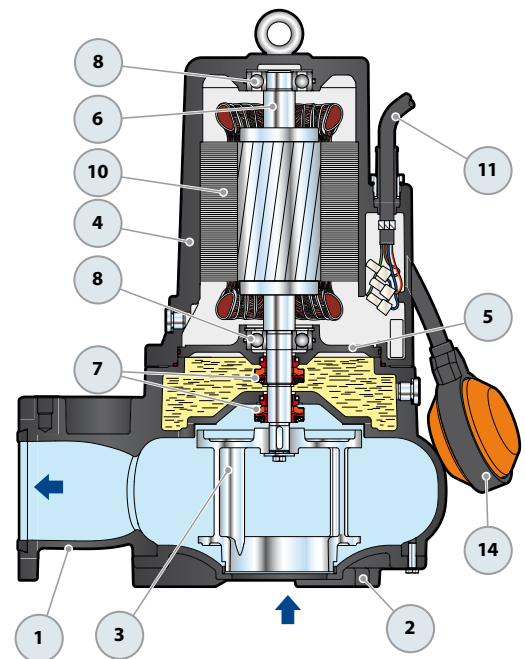

11 POWER CABLE

10 metres long "H07 RN-F" cable

12 CONTROL BOX for MCm 15-20-F

(only for single-phase versions)

Complete with capacitor and manual reset motor protector

13 CONTROL BOX for MCm 30-F

(only for single-phase versions)

QES 300 MONO series

14 FLOAT SWITCH

(only for single-phase versions)

Standard features

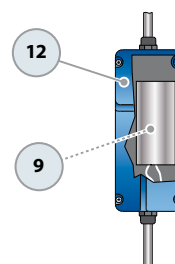

Control box for MCm 15-20-F (HP 1.5-2.0) (only for single-phase versions)

Standard features

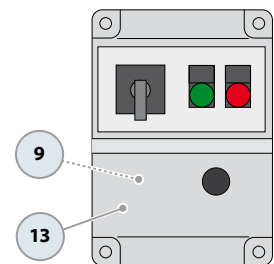

Control box for MCm 30-F (HP 3.0) (only for single-phase versions)

DIMENSIONS AND WEIGHT

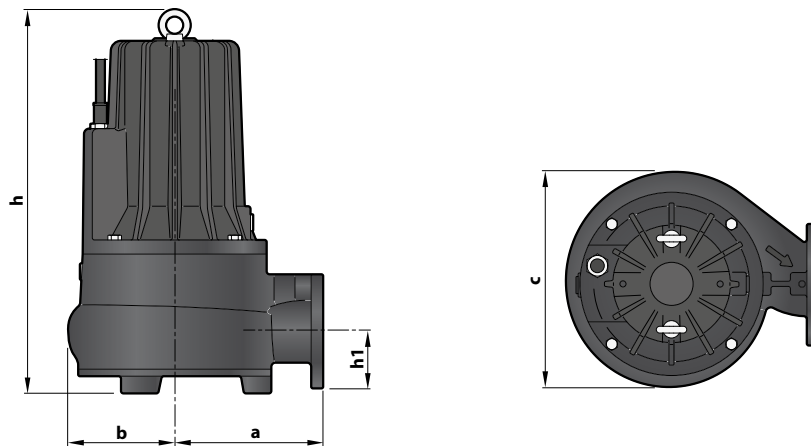

MODEL		Passage of solids	DIMENSIONS mm					kg	
Single-phase	Three-phase		a	b	c	h	h1	1~	3~
MCm 15/50-F	MC 15/50-F	Ø 50 mm	169	122	248	442	65	36.4	35.0
MCm 20/50-F	MC 20/50-F					457 / 442		38.7	34.0
MCm 30/50-F	MC 30/50-F					457		41.7	38.3
-	MC 40/50-F					457		-	42.3
MCm 30/70-F	MC 30/70-F	Ø 70 mm	205	131	268	472 / 458	70	42.9	38.5
-	MC 40/70-F					472		-	43.9

PORT FLANGE

MODEL	F mm	K mm	L mm	H mm	HOLES	
					N°	Ø (mm)
MC /50-F	58	145	140	130	4	17
MC /70-F	76		140	140		

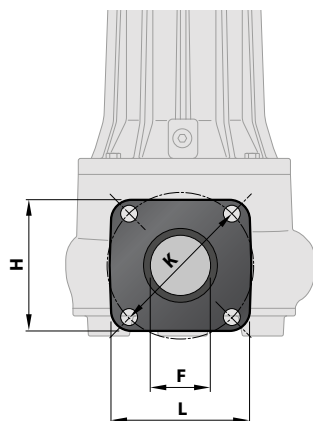

ABSORPTION

MODEL	VOLTAGE	
	230 V	240 V
Single-phase	230 V	240 V
MCm 15/50-F	9.0 A	8.9 A
MCm 20/50-F	10.5 A	10.4 A
MCm 30/50-F	15.2 A	15.1 A
MCm 30/70-F	15.2 A	15.1 A

MODEL	VOLTAGE		
	230÷240 V	400÷415 V	690÷720 V
Three-phase	230÷240 V	400÷415 V	690÷720 V
MC 15/50-F	6.1 A	3.5 A	2.0 A
MC 20/50-F	7.4 A	4.3 A	2.5 A
MC 30/50-F	9.9 A	5.7 A	3.3 A
MC 40/50-F	13.5 A	7.8 A	4.5 A
MC 30/70-F	10.2 A	5.9 A	3.4 A
MC 40/70-F	13.5 A	7.8 A	4.5 A

BASE PEDESTAL KIT VXC-F – MC-F

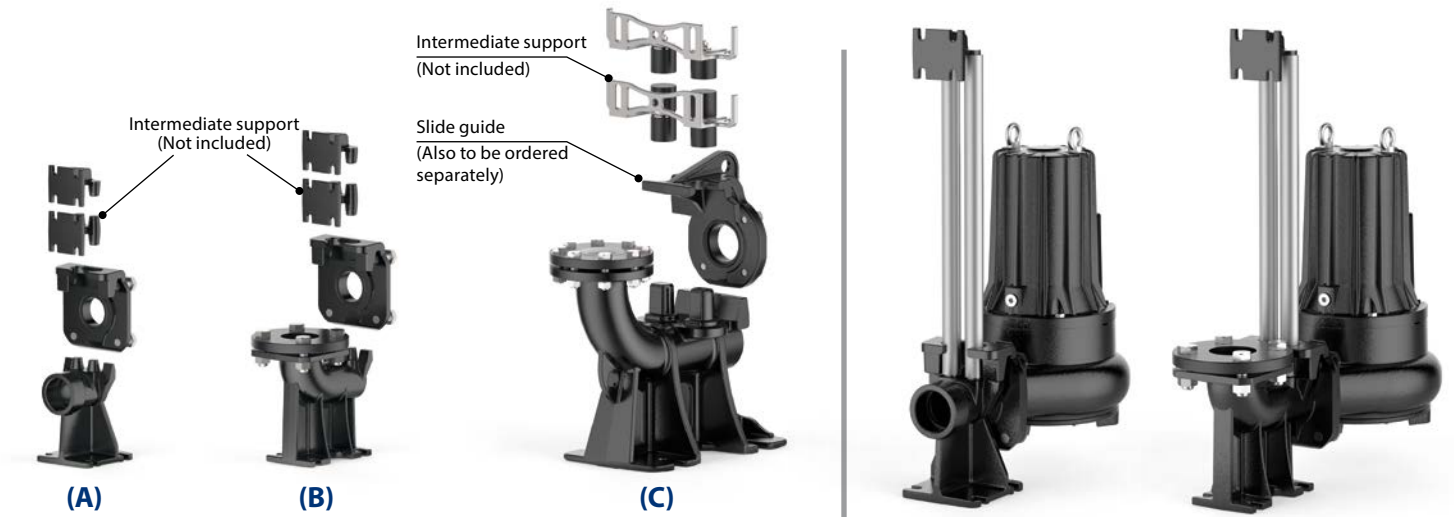

A) HORIZONTAL DELIVERY VERSION WITH ¾" GUIDE TUBES

For VXC /50-F, MC /50-F	Cod. ASSVXCF050	DN 2"
--------------------------------	-----------------	--------------

Kit consisting of:

- footing connection
- slide guide with screws and seals
- support for the guide tubes

B) VERTICAL DELIVERY VERSION WITH ¾" GUIDE TUBES

For VXC /50-F, MC /50-F	Cod. ASSVXCF050V	DN 2½"
For VXC /70-F, MC /70-F	Cod. ASSVXCF070V	DN 3"

Kit consisting of:

- footing connection complete with counterflange
- slide guide with screws and seals
- support for the guide tubes

C) VERTICAL DELIVERY VERSION WITH 2" GUIDE TUBES

For VXC /50-F, MC /50-F	Cod. ASSVXCF0703V	DN 3"
For VXC /70-F, MC /70-F		

Kit consisting of:

- footing connection complete with counterflange
- slide guide with screws and seals
- support for the guide tubes

SLIDE GUIDE (Also to be ordered separately)

For VXC /50-F, MC /50-F	Cod. ASSFL070
For VXC /70-F, MC /70-F	

Complete with screws and seals

INTERMEDIATE SUPPORT (To be ordered separately)

Cod. 859SV340INTFA	For guide tubes Ø ¾"
Cod. 859SV349INTFA	For guide tubes Ø 2"

GUIDE TUBES (AISI 304 stainless steel)

Cod. 54SARTG005	Ø ¾"
Cod. 54SARTG006	Ø 2"

In order to ensure stability, insert the intermediate support:

- every 2 metres with ¾" guide tubes (compulsory)
- every 3 metres with 2" guide tubes (recommended)

Maximum length of the tube plank: 6 metres

STANDARD INSTALLATION

1. Pump
2. Footing connection
3. Guide tubes
4. Support for the guide tubes
5. Lifting chain
6. Control box
7. Alarm float switch
8. Starting float switch
9. Stop float switch
10. Non-return valve

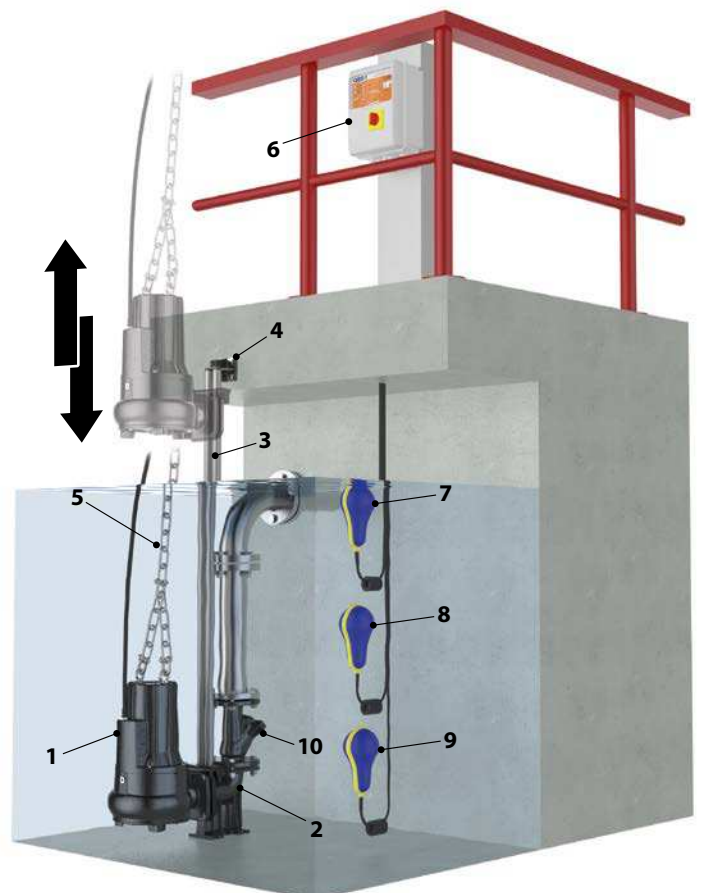

DIMENSIONS (Horizontal delivery version)

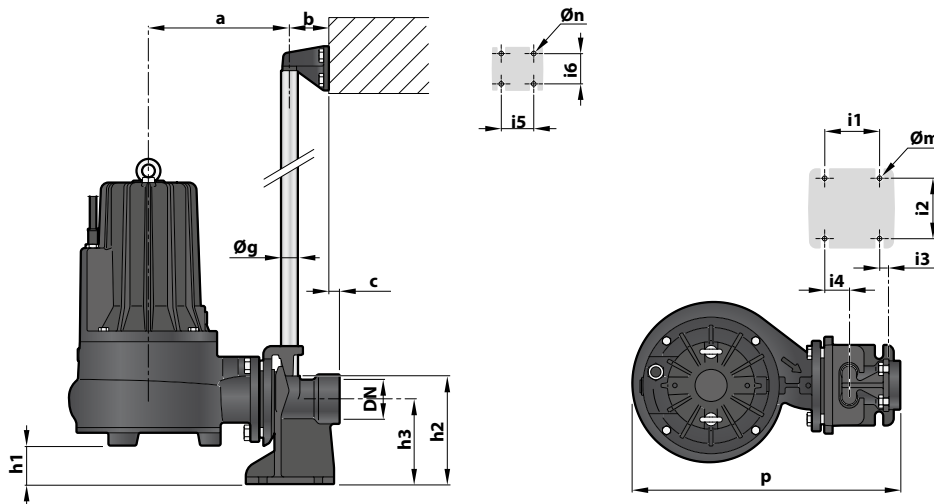

MODEL	Passage of solids mm	PORT DN	DIMENSIONS mm																
			a	b	c	p	h1	h2	h3	i1	i2	i3	i4	i5	i6	Øg	Øm	Øn	
VXC /50-F	Ø 50	2"	215	61	17	414	60	165	130	85	94	16	40	50	48	¾"	12	11	
MC /50-F																			

DIMENSIONS (Vertical delivery version)

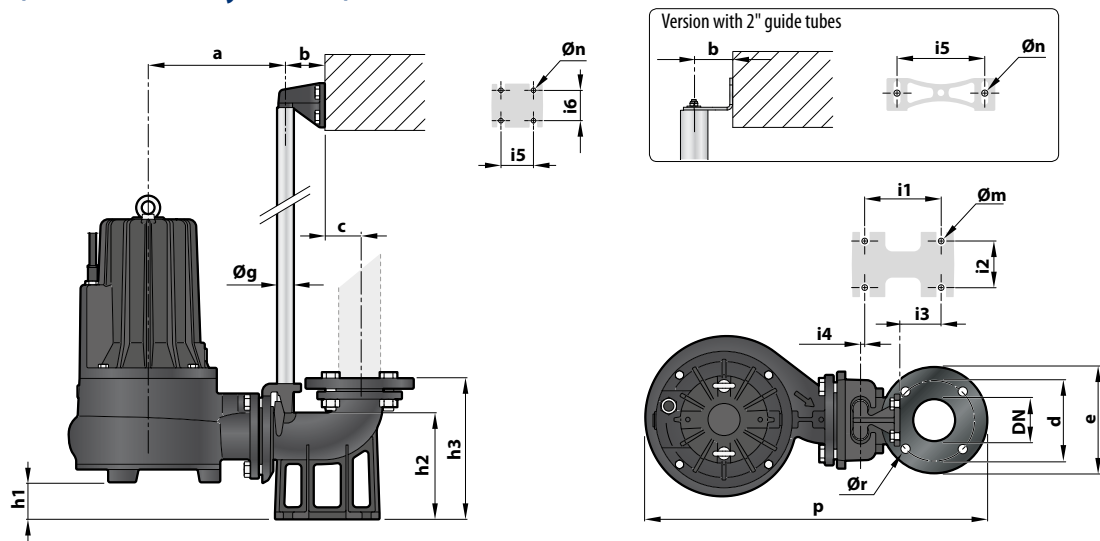

Version with ¾" guide tubes

MODEL	Passage of solids mm	PORT DN	DIMENSIONS mm																		
			a	b	c	d	e	p	h1	h2	h3	i1	i2	i3	i4	i5	i6	Øg	Øm	Øn	Ør
VXC /50-F	Ø 50	2½" (PN10)	212	61	52	125	165	528	57	164	215	120	72	62	3	50	48	¾"	14	11	18
MC /50-F																					
VXC /70-F	Ø 70	3" (PN6)	247	61	69	150	190	603	94	216	279	130	112	84	15	50	48	¾"	14	11	18
MC /70-F																					

Version with 2" guide tubes

MODEL	Passage of solids mm	PORT DN	DIMENSIONS mm																		
			a	b	c	d	e	p	h1	h2	h3	i1	i2	i3	i4	i5	i6	Øg	Øm	Øn	Ør
VXC /50-F	Ø 50	3" (PN10)	318	86	95	160	200	720	137	265	392	250	150	34	-	187	-	2"	22	13	18
MC /50-F																					
VXC /70-F	Ø 70	3" (PN10)	354	86	95	160	200	765	132	265	392	250	150	34	-	187	-	2"	22	13	18
MC /70-F																					