

Compact 2 & 22

Automatic Device for electric pump integral control.

The COMPACT 2 & 22 are a compact device for the automatic control and protection of electric pumps, its patented system includes special electronic sensor of flow and pressure, integrated in electronic circuit that guides the electric pump operation and keeps pressure and flow accordingly. Moreover, it has a safety system to avoid the dry-running operation.

The COMPACT 2 & 22 replace the system of hydrosphere, pressure-switch, check-valve and level switches, with the advantage of smaller dimensions and periodic maintenance elimination. The unit automatically starts the electric pump when any point of use is open and stop it –after a 10 seconds programmed time– when closing the consumption point.

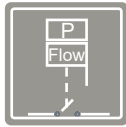

COMPACT 2 F10

COMPACT 2 F15

COMPACT 2 R

COMPACT 22 F10

COMPACT 22 F15

COMPACT 22 R



OPERATING CHARACTERISTICS

- No maintenance.
- Installation time saving.
- Protection against water hammer effect.
- Compact and reduced dimensions.
- Removal of protecting devices (level switches).
- Avoids the pump oversizing using integrately their flowpressure curve.
- Integrated protection system which stops the pump in case of dry-running operation.
- Control panel:
 - Yellow Led POWER.
 - Green Led ON.
 - Red Led FAILURE.
- Tactile push button for manual start.
- Electronic circuit group with protection cover easily replaceable.
- Small reserve against leaks in the installation.
- Other options like pressure gauge, connecting cables, adjustable starting pressure.
- EMC and electrical safety certified.
- ART function (Automatic Reset Test). If the device has been stopped due to the action of the safety system against dry operation, the ART tries to connect the pump, with a programmed periodicity because the water supply could have been restored

TECHNICAL CHARACTERISTICS

	COMPACT 2 F10	COMPACT 2 F15	COMPACT 2 R	COMPACT 22 F10	COMPACT 22 F15	COMPACT 22 R
Start pressure	1 bar	1,5 bar	1,5-3,5 bar	1 bar	1,5 bar	1,5-4,5 bar
Power	1,5 kW	1,5 kW	1,5 kW	2,2 kW	2,2 kW	2,2 kW
Voltage	~1x120 V ~1x230 V	~1x120 V ~1x230 V	~1x120 V ~1x230 V	~1x120 V ~1x230 V	~1x120 V ~1x230 V	~1x120 V ~1x230 V
Frequency	50/60 Hz	50/60 Hz	50/60 Hz	50/60 Hz	50/60 Hz	50/60 Hz
Max peak of current	10 A; cos fi ≥0.6	10 A; cos fi ≥0.6	10 A; cos fi ≥0.6	16 A; cos fi ≥0.6	16 A; cos fi ≥0.6	16 A; cos fi ≥0.6
Protection degree	IP65	IP65	IP65	IP65	IP65	IP65
Maximum temperature	50 °C	50 °C	50 °C	50 °C	50 °C	50 °C
Maximum pressure	10 bar	10 bar	10 bar	10 bar	10 bar	10 bar
Maximum flow	8.000 l/h	8.000 l/h	8.000 l/h	8.000 l/h	8.000 l/h	8.000 l/h
Net weight (without cables)	0,719 Kg	0,719 Kg	0,719 Kg	0,719 Kg	0,719 Kg	0,719 Kg

CONTROL PANEL

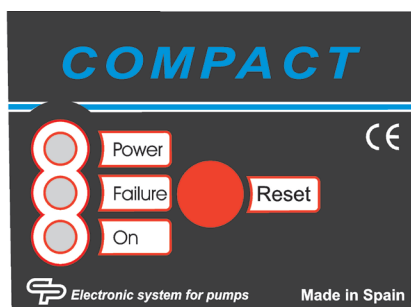

DIMENSIONS

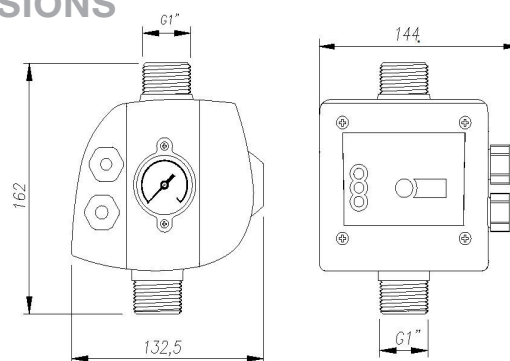

INSTALLATION

